

Interconnexion électrique

Maroc – Algérie

1200 MW



Morocco-Spain interconnection:

- 15~20% of Morocco's Electricity imported (4~5 TWhr)
- Reversed flow interconnection benefit both systems
 - 2006 EU German-Spain blackout repercussions quick back-up
 - 2010 Morocco's Excess hydropower evacuation
- Morocco ONE-Algeria SONEGAS agreement (2008)
Power from Algerian grid can be sold via Morocco on Iberian system
Limited capacities to be reinforced by MEDRING

Mediterranean sea

Interconnexion électrique

Maroc – Espagne

1400 MW

South Spain



Gibraltar strait



North Morocco

Gazoduc
Maghreb Europe
12,5 bcm

Sahara Trade Wind Resource: NATO 'Science for Peace' SfP-982620



Trade Winds Existed for Millions of years
Geological Evidence:
World's Largest Sedimentary Phosphate deposits

- ▲ Phosphate deposits (42% of World reserves)

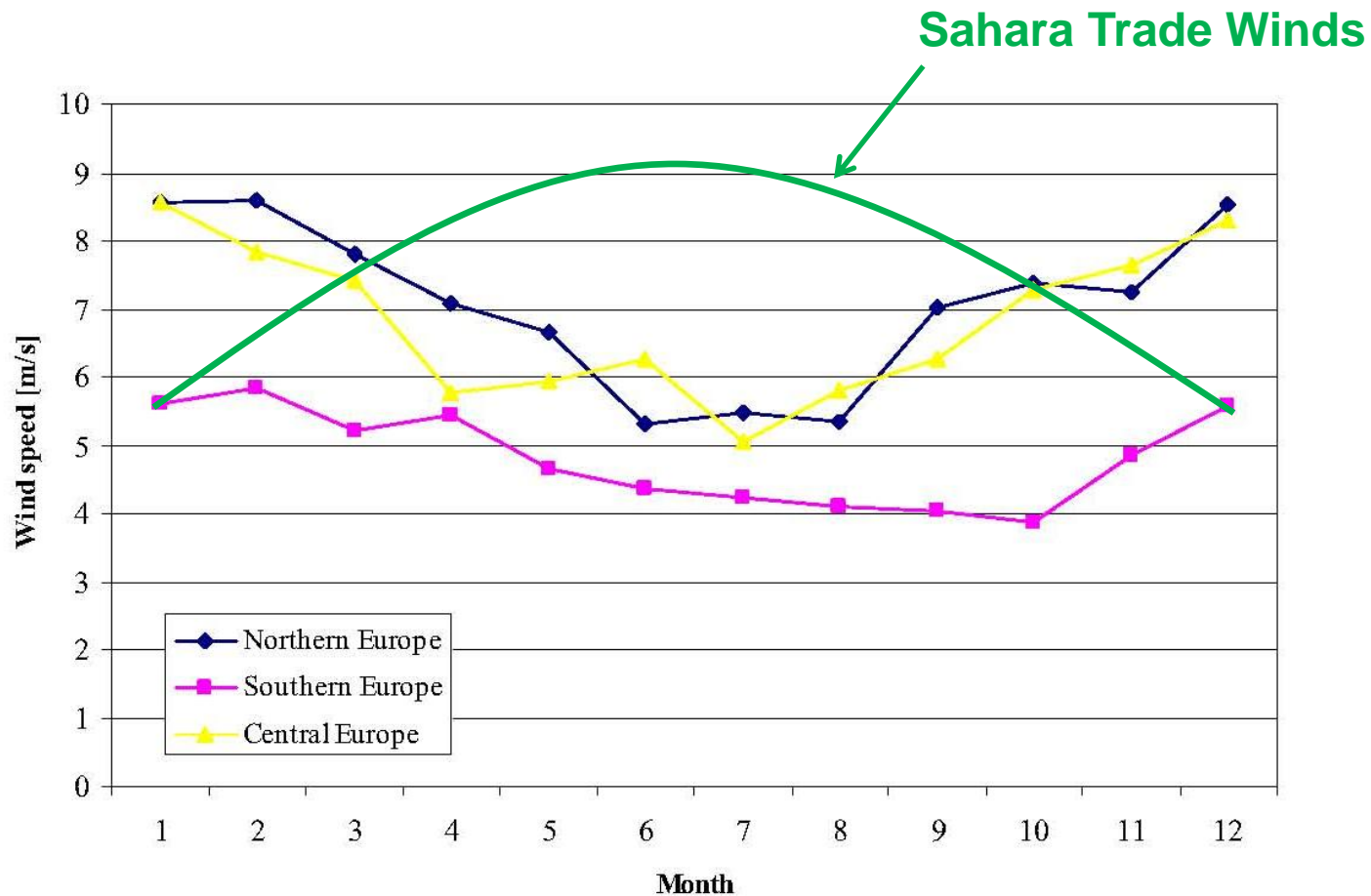

Figure 2.4 Seasonal trends in Reanalysis wind speed

Morocco's Integrated Wind Energy Program: 2GW

National Program (Export Possibility Not Included)

- 2011: 1 GW (280 MW Built with 720 MW planned/under construction)
- 2020:+1 GW (1000 MW Morocco Integrated Wind Energy Program)
2 GW Total

Limiting factor: Grid Size!

- Total Power Generating Capacity 6405 MW, Peak Load 4890 MW
⇒ Wind Power Integration is Challenging Beyond 2 GW
- Sahara Trade Wind Potential Away From Closest Load Centers (1000 km+)
- Transferring Power & Wind Industry Requires Larger Capacities
⇒ A Regional Project Development Approach is needed:

The Sahara Wind-HVDC Project (5GW+)

- Sahara Wind: from Idea to Project -

- **1993**: Initial wind measurements installed (Sahara Trade Wind Region)
- **1994**: Report on Sahara trade wind energy potential to H.M. King Hassan II
- **1994-97**: Wind-Diesel-Hybrid small grids system tested with variable loads
- **1997-1999**: EU-Level discussions (Commission & Parliament) over export of wind electricity to Europe from the Saharan Atlantic trade winds (Sahara Wind Project).
- **2002**: Sahara Wind Project presented the at the European Parliament (2002), USA - Africa Ministerial (2002), WWEC 2003, Bonn Renewables 2004, etc...
- **2003-2005**: Joint World Bank-AfDB UNDP/GEF PIMS #3292 “Morocco Sahara Wind Phase I / Tafaya (400-500 MW) On-Grid Wind Electricity in a Liberalized Market”. Public-Private Partnership with Ministry of Energy with Terms of References of Project Phasing & HVDC line with ONE (Morocco utility) on the base of 5000 MW to supply EU-Mediterranean markets.
- **2005-Present**: Regional Project Development Activities – Integrative Processes with Support from UNIDO, IPHE (World Hydrogen Project), IEA, USA-Morocco S&T Agreement, NATO (Science for Peace) Extensive Wind Measurements, Training, Capacity Building, Industry-Academia Partnerships in Morocco & Mauritania, Pilot Projects Deployment , etc.

Scénario alternatif : Sahara Wind

Hypothèses :

- 5 GW supplémentaires installés en 2020
- Intégration industrielle 95%
- 500 MW installés/an en 2016 et 2017
- 1 000 MW installés/an en 2018 et 2019
- 2 000 MW installés en 2020

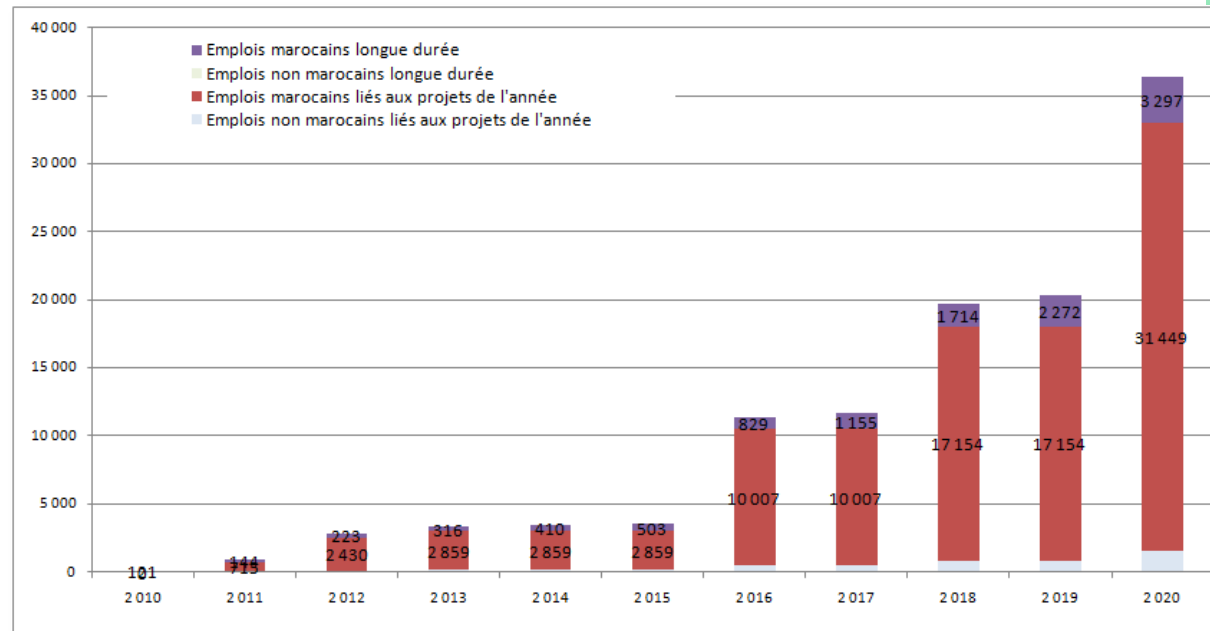
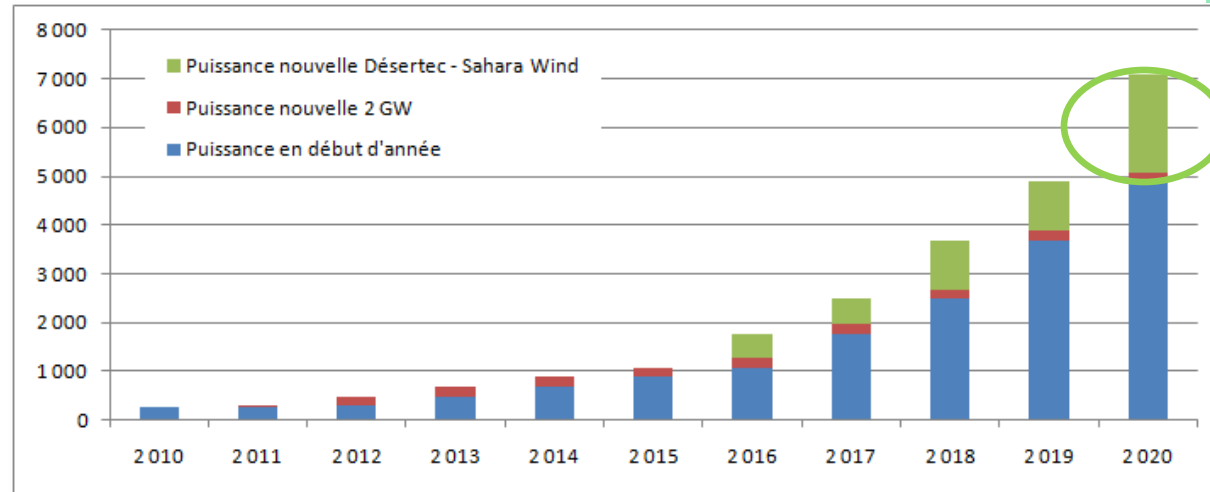

Emplois non marocains liés aux projets de l'année	1 551
Emplois marocains liés aux projets de l'année	31 449
Emplois non marocains longue durée	30
Emplois marocains longue durée	3 297
Total	36 327



Sahara Wind Project

Phasing and Gradual Deployment

Sahara Wind - Phase I : 50~500 MW (2012-2016) Grid Impact Studies/Project Phasing with ONE (Transmission System Operator), NATO (SfP-982620) Wind Measurements, Training, Capacity Building, Pilot Projects/Industrial Synergies with ONEP–ONEE... Supported by Morocco Energy Fund, GEF, WB-CTF, EBI ...

Sahara Wind - Phase II : 500 MW ~ 5 GW (2016-2020)

- 500 MW x 2 Project Clusters / 1st bi-pole 5 GW – HVDC
- 1000 MW x 2 Project Clusters / 1st bi-pole 5 GW – HVDC

Sahara Wind - Phase III : 5 ~ 10 GW (2020+)

- 2500 MW x 2 Project Clusters / 2nd bi-pole 5 GW - HVDC

Optimization of HVDC line infrastructure (up to 10 GW of HVDC Transfer capacity)
Sahara Wind Morocco-Iberian Line can be Extended Further into France, Germany...

Complementary to :

- Moroccan Integrated Wind Program : 2 GW (by 2020)
- Moroccan Solar Plan (Concentrated Solar Thermal + PV): 2 GW (by 2020)
- Mediterranean Solar Plan (MSP): 20 GW (by 2020) Sahara Wind Project - Phase I Pilot Project presented to Immediate Action Plan of MSP (11/2008)

Sahara Wind Energy Development Project

Research, Development & Demonstration – Integral Part of Sahara Wind Project
Sahara Wind Phase 1: 50~500 MW on existing grid / Extensions through HVDC lines

HVDC Technology:

- Limited losses –long distance (5% over 1500 Km \pm 500kV for 5000 MW)
- 140 GW of HVDC in 145 Projects worldwide: China 25 multi-GW projects planned (2010), USA 10 multi-GW projects (2011), India, Brazil, Canada..

North African and Euro-Mediterranean electricity markets in high growth/expansion

Wind catchment area:

- Average wind speed: 8~9 m/s (Trade Winds)
- Size of Area: Saharan coast 2000 km+ (Morocco, Mauritania & Senegal)
- Potential Wind Energy 500 GW(?) ~ 1000 TWhr(?)

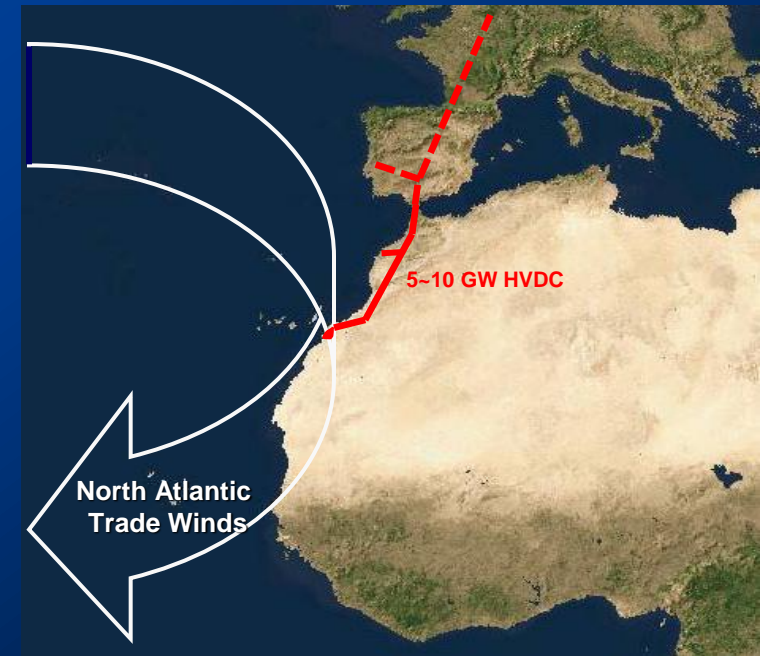

Figure 1 : Sahara Wind - HVDC Transmission Architecture 5 GW - bipole 1 (Point to Point configuration classical HVDC)

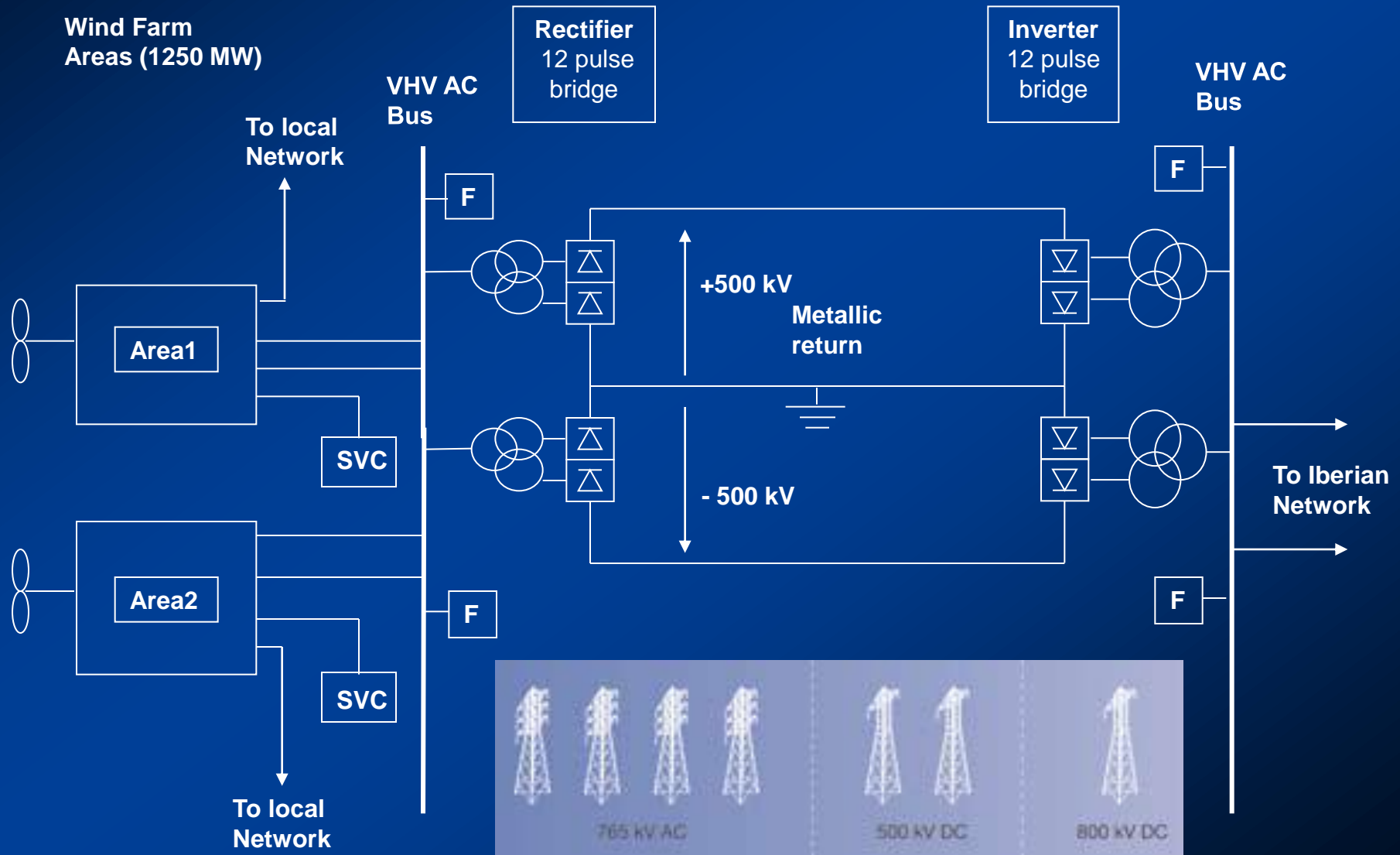

Figure 4 : Sahara Wind - HVDC Transmission Architecture - bipole 1 (5GW)
(Multipoint Point configuration SVC Technology)

